

# TotalFlo™

## Jet Pumps and Multistage Pumps

### Installation and Operating Instructions



Please pass these instructions on to the operator of this equipment.



**SOLAR WARNING: This Equipment is not suitable for use with Solar Panel Power Supply.**

Congratulations on your purchase of an TotalFlo quality water pressure system. All components have been designed and manufactured to give trouble free, reliable operation.

**Before installing your new pump, please read all instructions carefully as failures caused by incorrect installation or operation are not covered by the guarantee. Your pump is designed to handle clean water. The pump should not be used for any other purpose without specific referral to your TotalFlo reseller. The use of the pump to handle flammable, corrosive and other materials of a hazardous nature is specifically excluded.**

1. Delivery outlet - 1" BSP(M)
2. Suction inlet - 1" BSP(F) for TF40J and TF50J  
1 1/4" BSP(F) for TF117MS
3. Pump body
4. Motor
5. Priming port and plug
6. Drain port and plug
7. Pressure Controller

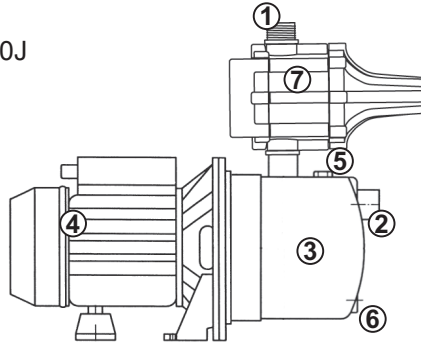

Maximum Total Head:

TF40J = 35m

TF50J = 41m

TF117MS = 41m



**Do not use this pump to pump flammable fluids, such as petrol or diesel fuels. This pump is designed to pump clean fresh water free of solids.**

## Choosing a Site

Choose a site with a firm base and as close to the water source as possible with correct power supply. Make sure your pump is always connected to an adequate, reliable source of clean water.

## Housing your Jet Pump or Multistage Pump

To protect your pump from the weather, make sure the cover provided is water proof, frost free and has adequate ventilation.

The pump should be horizontally mounted on a firm base allowing for drainage, to avoid damage to flooring etc., that over time may occur from leaking pipe joints or pump seals. Do not mount the pump vertically.

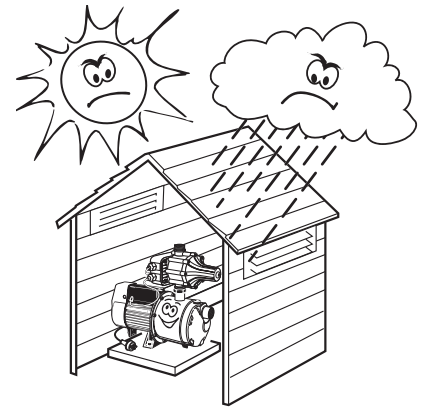

**WARNING: Some insects, such as small ants, find electrical devices attractive for various reasons. If your pump enclosure is susceptible to insect infestation you should implement a suitable pest control plan.**

## Power Connection

The pump motor is fitted with an earthed three pin plug & lead.

The installer is responsible for the correct connection of the electrical supply to the pump motor.

- Make sure the supply voltage and frequency is the same as the nameplate.
- Make sure that there is a sound earth connection available.

In accordance with AS/NZS 60335.2.41 we are obliged to inform you that this pump is not to be used by children or infirm persons and must not be used as a toy by children. This appliance is not intended for use by persons (including children) with reduced physical, sensory or mental capabilities, or lack of experience and knowledge, unless they have been given supervision or instruction concerning use of the appliance by a person responsible for their safety. Children should be supervised to ensure that they don't play with the appliance.



### POWER CONNECTION

Connect lead to power supply designated on pump label. Do not use long extension leads as they cause substantial voltage drop, poor pump performance and may cause motor overload.



### EARTH CONNECTION

The pump power lead includes an earth pin on the plug, which **MUST** be correctly connected to a suitable earth on the electrical supply.

If the supply cord is damaged, it must be replaced by the manufacturer, its service agent or similarly qualified persons in order to avoid a hazard.

## Electrical Power Surge Protection

An electrical power surge or spike can travel on the supply lines and cause serious damage to your electrical equipment. The controller fitted to this pump has a metal oxide varistor (MOV) fitted to help protect it's circuit. This MOV is a "sacrificial" device, meaning that it effectively gradually destroys itself every time it takes a surge. The MOV is not a lightning arrestor and may not protect the controller if lightning or a very powerful surge hits the pump unit.

If the installation is subject to electrical power surges or lightning we strongly recommend the use of a suitable surge protection device on ALL electrical equipment.

## Pipe Connections

For best performance use P.V.C. or polythene pipes at least the same diameter as the pumps inlet and delivery outlet openings. Larger diameter pipe may be used to minimise resistance to flow when pumping longer distances.

Use unions as pipe connections to enable easy removal and servicing. Use sufficient tape to ensure airtight seal and hand tighten only. To prevent strain on pump threads always support heavy inlet and outlet pipes. If there is a likelihood the water supply may contain solid particles such as pieces of plant or vegetable matter, a suction strainer should be installed before the pump to avoid blocking of the pump. Lay suction pipe at a constant gradient to avoid air pockets which reduce pump efficiency.



**NOTE - Suction leaks are the largest cause of poor pump performance and are difficult to detect. Ensure all connections are completely sealed USING THREAD TAPE ONLY.**

## Installations with a Suction Lift

Installations with a suction lift require a good quality foot valve to avoid loss of prime.

## Installations with Flooded Suction

Installations with flooded suction require a gate valve so water supply can be turned off for pump removal and servicing.



**WARNING  
DO NOT RUN DRY.  
DO NOT RUN WITH LOSS OF PRIME.  
DO NOT PUMP WATER CONTAINING ABRASIVE MATERIALS.**

## Abrasive Materials

The pumping of abrasive materials will cause damage to the pump which will then not be covered by the guarantee.



**Water temperature in pump must not exceed 35°C, or damage caused will not be covered by guarantee.**

## Connection of Mains Scheme or Town Water Supply to either Suction or Discharge of Pump

Most Water Supply Authorities have strict regulations regarding direct connection of pumps to mains water supplies. In most cases an isolating tank is required between mains supply and pump. This is also the recommend method for this pump. Directly applied mains pressure can exceed pump operating pressure and damage pump.

**TotalFlo can not accept responsibility for loss or damage resulting from incorrect or unauthorised installations.**

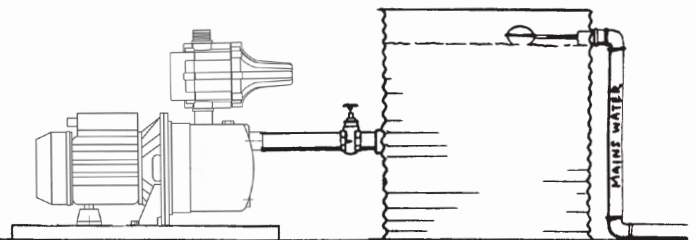

**NOTE - If connecting your pump direct to mains water, the casing pressure (maximum outlet pressure) must not exceed 600kPa (6bar/87psi).**

## Priming and Operation

### Automatic Water Pressure System

1. Fill pump and suction line through the pump discharge or priming port (on flooded suction, simply open gate valve to pump).
2. Ensure outlet nearest to pump is open.
3. Ensure all valves in suction line are open and switch on pump at power outlet. There will be a delay of less than 1 second before the pump starts.
4. Prime should establish almost immediately and a strong flow of water should be evident from the outlet. Allow water to flow for 10-20 seconds to expel air then close outlet. Pump will switch off shortly after and wait in standby until a drop in pressure initiates a pump start.
5. If no flow is evident from tap, switch off at power point and repeat from step 1 ensuring there is an adequate supply of water available to the pump.
6. If the pump does not automatically restart on re-opening of tap, consult trouble shooting guide.

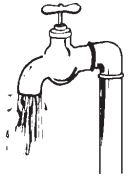

### Automatic Pressure Controller

The unit is pre-set at a restarting pressure of 150kPa. The pump will stop at approximately 0.5lpm. If the pump reaches above 230kPa at low flow stop, then it will go to standby. If the pressure has not risen at low flow the controller will detect a fault.

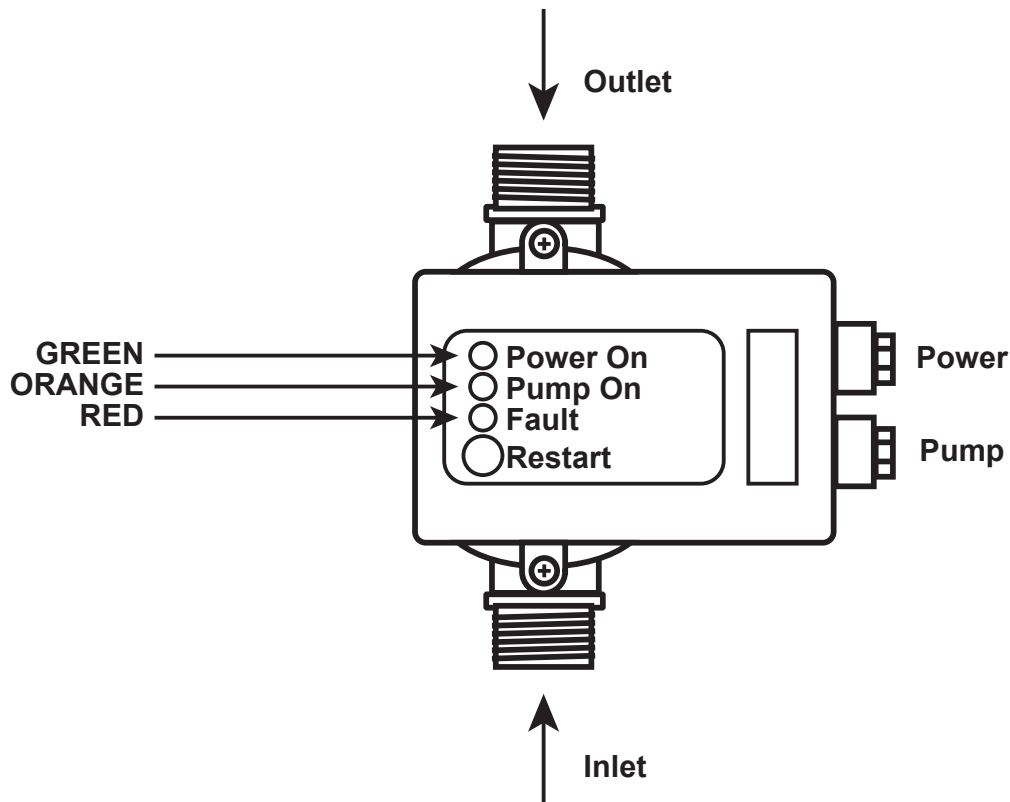

Never operate your pump for more than several seconds without discharge flow.



**NOTE:** If the static discharge head (vertical height) above the pump exceeds 15m, the Automatic Pressure Controller will not allow the pump to start. Consult your TotalFlo dealer for advice.

# Trouble Shooting Check List

## MOTOR DOESN'T START WHEN SWITCHED ON

1. Power not connected.
2. Supply voltage too low.
3. "Over temperature" cut-out tripped.
4. Motor not free to turn eg. a jammed impeller.
5. Internal motor fault.

## MOTOR DOES NOT START WHEN TAP IS OPENED

1. Automatic switch has detected loss of prime.
2. The static head (vertical height) above the pump to the outlet is greater than 15m.

## MOTOR RUNS WHEN SWITCHED ON BUT DOES NOT PUMP

1. Suction line and pump body not filled with water.
2. Air leaks in suction lines or suction pipe not under water.
3. Air trapped in suction lines (also possible with flooded suction due to uneven rise in piping; eliminate humps and hollows).
4. No water at source or water level too low.
5. Valve on suction lines closed.

## MOTOR RUNS WHEN SWITCHED ON BUT DOES NOT PUMP, PUMPS POORLY OR FAULT LIGHT IS LIT (PUMP STOPS)

1. Suction line and pump body not filled with water.
2. Air leaks in suction lines or suction pipe not under water.
3. Air trapped in suction lines (also possible with flooded suction due to uneven rise in piping; eliminate humps and hollows).
4. No water at source or water level too low.
5. Valve on suction lines closed.
6. Check valve installed in wrong direction.
7. Suction lift too high.
8. Leaking air bleed screw.
9. Blocked jet or venturi – jet pumps only.
10. Blocked impeller.

## PUMP STOPS, BUT RESTARTS QUICKLY - NO FLOW DEMAND

1. Leaking suction line, checkvalve or footvalve.
2. Suction pipe too long and/or too flexible.

## PUMP DOESN'T SUPPLY ADEQUATE PRESSURE

1. Suction lift is too high.
2. Pump impellers partially blocked.
3. Jet blocked – jet pumps only.
4. Partially blocked suction line.
5. Wrong pump selected.
6. Change the installation.



**NOTE:** For protection, the pump motor is fitted with an automatic "over temperature" cut-out. Constant tripping of this overload device indicates a problem eg. low voltage at pump, excessive temperature (above 50°C) in pump enclosure.



**WARNING -** When servicing or attending pump, always ensure power is switched off and lead unplugged. Electrical connections should be serviced only by qualified persons.



Care should also be taken when servicing or disassembling pump to avoid possible injury from hot pressurised water. Unplug pump, relieve pressure by opening a tap on the discharge side of the pump and allow any hot water in pump to cool before attempting to dismantle.



During servicing, use only approved, non-petrochemical based oring and gasket lubrication. If unsure, consult your TotalFlo Dealer for advice.





# TotalFlo Warranty\*

TotalFlo products will be (under normal use and service) free of defects in material and workmanship from the date of original purchase for the period specified under the Warranty Period.

Warranty Period: 12 months

**As notified, no spare parts or repair facilities (infield or workshop service) are available for TotalFlo products. If your TotalFlo product is defective we will replace the TotalFlo product free of charge.**

## TotalFlo Warranty Procedure:

- Problem solve using the Installation & Operating Instructions, especially the troubleshooting sections. If this does not solve the problem, or the product is suspected of being defective, stop using it and contact the original place of purchase for advice.
- If the dealer you purchased the TotalFlo product from could not help you resolve the issue, they may require you to return the product to them for review and inspection. Returning the product to the place of purchase is at your cost and is your responsibility. You must provide evidence of the date of original purchase (i.e. dated receipt) as proof of purchase.
- The warranty claim will be assessed by us on the basis of our product knowledge and reasonable judgement and will be accepted if:
  - a relevant defect is found
  - the warranty claim is made during the relevant Warranty Period; and
  - none of the excluded conditions listed below apply
- You will be notified of the warranty decision, and if it has been accepted your replacement product will be dispatched to the dealer for collection from where you purchased it from. If your warranty claim is found to be invalid you must organise collection of the product at your expense or authorise its disposal.

The TotalFlo warranty does not cover normal wear and tear or apply to a product that has:

- been subject to misuse, neglect, negligence, damage or accident
- not been used, operated or maintained in accordance with the Installation and Operating Instructions
- not been installed in accordance with the specified instructions or by suitably qualified personnel
- been modified or altered from original specification, had repairs attempted or tampered with in any way
- been subject to conditions such as incorrect voltage supply, lightning or high voltage spikes, or damage or
- breakdown from exposure to electrolytic action, cavitation, sand, corrosive, saline or abrasive liquids.

To the extent permitted by law, we shall not be liable for any loss of profits or any consequential, indirect or special loss, damage or injury of any kind whatsoever arising directly or indirectly from TotalFlo products. This limitation does not apply to our liability for failure to comply with a statutory consumer guarantee applicable to your TotalFlo product under local laws and does not affect any corresponding rights or remedies that may be available to you under local laws.

In this regard, our goods come with guarantees that cannot be excluded under certain consumer laws (including the Australian Consumer Law). For example, if you purchase our goods in Australia you are entitled to a replacement or refund for a major failure and compensation for any other reasonably foreseeable loss or damage. You are also entitled to have the goods repaired or replaced if the goods fail to be of acceptable quality and the failure does not amount to a major failure.

\* The TotalFlo warranty is in addition to any rights provided by consumer protection laws and regulations in the country of purchase. Should your product be defective you can choose to make a claim under applicable consumer laws or the TotalFlo warranty.

A Quick Reference Guide is included with the product when purchased new and for detailed Installation and Operating Instructions please visit [TOTALFLOPUMPS.COM](http://TOTALFLOPUMPS.COM).

This warranty is given by Davey Water Products Pty Ltd. For further information, please contact us at:

---

# TotalFlo<sup>TM</sup>

## DAVEY

ABN 18 066 327 517

### ASIA / INTERNATIONAL

Davey Water Products Pty Ltd

(Located in Australia)

6 Lakeview Drive,

Scoresby, Victoria, Australia 3179

Ph: +61 3 9730 92222

Website: [totalflopumps.com](http://totalflopumps.com)

<sup>TM</sup> TotalFlo is a trade mark of Davey Water Products Pty Ltd

DWP1925-1

---

**Note: Only the Quick Reference Guide is included with the product when purchased new. For full installation and operating instructions visit [totalflopumps.com](http://totalflopumps.com)**